

Accessory Machine Used for Single-phase Complex Agro Technology

Zoran S. Veselinovic^{1*}

¹Department of Agroengineering and Marketing, D.O.O, Prijedor, Veliko Palančište b.b., Bosnia and Herzegovina.

Author's contribution

The sole author designed, analysed, interpreted and prepared the manuscript.

Article Information

Editor(s):

(1) Dr. Fatima Lizeth Gandarilla-Pacheco, Universidad Autónoma de Nuevo León, Mexico.

Reviewers:

(1) Aba-toumnou Lucie, University of Bangui, Central African Republic.

(2) Lu Wei, Nanjing Agricultural University, China.

(3) Zulhishamuddin Abd Rahman, Kuantan Polytechnic, Malaysia.

Complete Peer review History: <http://www.sdiarticle4.com/review-history/54747>

Short Communication

Received 16 January 2020

Accepted 21 March 2020

Published 07 April 2020

ABSTRACT

Accessory machine for single-phase complex agro-technology serves the sowing operation, and before that, and prepares the soil, which regulates all necessary physical and biological conditions for optimal growth and yield. With this physical operation, through the development, erosion, mixing and homogenization of the soil, the number of passages is reduced to only one, and the reduction is reduced to a minimum, factors which affect the physical, biological and chemical properties of the soil are preserved and enhanced. In addition to the precise individual laying of each seed, except for the desired depth, this machine in the seed mode, apart from the desired depth, performs their horizontal arrangement along the entire surface in the required spacing. The layers of the multilayer compaction and the handling of homogenized soil are arranged in a good arrangement and the connection of seeds and soils, faster germination and achieve the requirements of certain species for the compactness of the soil under and above the laid seeds. A homogenized distribution of nutrients throughout the cross-section is performed and a proper schedule of starting doses in-depth, protective serum, growth bioregulators and aggregate structuring.

Keywords: *Aggregated drill; multilayer soil preparation in one pass; single-use of all types of seeds.*

*Corresponding author: E-mail: aim@prijedor.com;

1. INTRODUCTION

Technological and technological progress altered the conditions in plant production, contributing to the improvement of the natural and financial effects, but remained one of the key factors of a fertility-the minimum of trials remained underdeveloped. The problem is how to achieve the minimal compaction of the land that is created by overgrowing due to a large number of passages in the stages of preparation until the end of the seed. In modern technology, the minimum land compaction has become a condition in achieving the most effective results of fertility. In that direction, and especially in the field of crop production, they were also leading all the tendencies of the development of mechanization. Conventional methods of soil treatment, based on the use of the sower plough as the main tool in the basic preparation, and the tools for supplementary treatment, this condition for raising fertility, the minimum punishment, were not met [1]. Although no one has foreseen such longevity, no one has foreseen such longevity, he has remained almost indescribable, true, with several successful improvements that will go towards the fulfilment of high demands in terms of demand. Various technical improvements and substitutions were also carried out on the tools: ploughs and harrows with combined grinders, and the like [2,3,4]. The use of heavy constructions, deep processing ropes, and various combinations: rippers and cultivators of wide-scale operations for additional processing or aggregation of several of them, and all, to minimize the passage and compaction - landing, were also used. etc.) [4]. Also, to reduce the hitting and then the effects of other effects (economics, organization, modern technology has a growing selection of tools for reduced processing, with more or more technical possibilities to meet the required requirements. However, such structures in one pass, the optimal requirements for seed, the so-called super-cultivators, are still constructively very complex and operatively demanded, which affects their massive use [5,6]. The latest technical solution for the minimum trimming is a docking machine for a single-phase complex agrotehnika. This machine can provide a complete solution to the problem of impacts that affect fertility and the needs of plants in the most optimal conditions in which their fertility will be maximized. The idea of the machine was created during the long-term analysis of the soil treatment impact on the growth, development and fertility of the plant through the motor drill of

the conventional methods. From the basic idea, there was a patent application, so the connection machine for single-phase complex agrotehnika has a national patent of BiH since 2009. During 2007 and 2008, the patent (at the time patent application) was exhibited at nine world patent exhibitions, and was rewarded with Gold medal at the innovation salon in Nuremberg, October 2007, Silver medals at innovation showrooms, Moscow in March 2007, Geneva in April 2007 and Warsaw in May 2007, Bronze medals at the Strasbourg Salons in September 2007 and Shanghai in April 2008.

2. METHODS

The docking machine for single-phase complex agro-technology is unique in that the new method achieves deep and surface treatment of the soil in only one passage, while minimizing the surface area of the traction, the length of the tractor wheel tracks, per unit area. Also, the minimum damage is removed by the hitch of the connecting machine.

The new land treatment method is based on the novelty in processing, by drilling, stretching, thinning and crushing to achieve the primary goal in cultivating land that is ready for sowing in only one pass. The smooth depth can be adjusted. This method of work is a novelty in agro-techniques, as it gives the following completely new and decisive advantages: in multi layered preparation of layers under and above the laid seeds and determining their degree of compactness and good preparation of the substrate for laying the seed and good connection with the soil, a sowing with which it is possible to better linearly distribute the seed in-depth and a novelty are available in the possibility of distributing the seed both in terms of width and distance, depending on the desired number of plants per unit area, which in Grain cultures that are sowing in strips or rows is never achieved. This is all with the aforementioned possibility of adjusting the compaction so that the team, in addition to a good connection of the seed with the soil, will provide capillary, faster germination and reduce the loss of humidity, • Homogenous distribution of nutrients is achieved in-depth, except that the starting doses can be distributed directly to the seed, • Establishment of the compound for the structuring of the aggregate of the soil, also the protection team, the bio-regulator of germination and growth, is achieved, and much better water and air regime is achieved in the soil.

In connection with this genetic potential, the plant has a potential for a higher fertility rate. Operations are performed with aggregated drills driven by the transmission mechanisms, frontally drilled and because of the changeable angle during the entry into the ground, cutting and cutting off the spiral layers, which, by lifting the spiral of the drill bits, blend and blast to the desired crumbly structure.

This soil treatment method gives the foundation of the new plant technology, and its advantages are:

- Preserve and promote factors that influence the physical, biological and chemical properties of the land and especially in the significant increase in water and air capacity, which are a condition for other fertility factors,
- They are reduced due to the varying degree of compactness in the wet layers, the loss of capillary moisture.
- Increases the degree of adhesion and capillary that accelerates faster germination and growth, In terms of financial effects about current technique, savings in fuel, lubricants, mechanical and living labour are achieved, and the organization is accelerated in all segments.

3. DESCRIPTION OF WORK

The drawing with Figs. 1 and 2 shows the attachment mechanism for a single-phase complex agrotehnika which gets a drive through a PTO shaft or a hydro engine. The basic structure is: Immobile part:

Bearing construction NK, which is three-point on the tractor as a carrier or semi-axial with side-mounted wheels: T. carrying,

- a. Depot for seeds DS with tubes: CS for the flow of seed to soil,
- b. Depot for fertilizer DG with piping system CG for fertilizer flow to the ground,
- c. Depot for the rest (pesticides, bioregulators, structuralists, etc.)
- d. Shaft O axis: Z and Z 1 driven by HM Hydraulic Motor that drives the drive to the moving part of the machine. Movement:
- e. Three-carrier rails: TN 1 and TN 2 driven through the Z2 and Z 3 gears with Z and Z1 gears from the O-axis rotate around their horizontal axis, with angles of 120° with

- support in the central part in which the driven shaft O1.sa three parallel-mounted gears: 2,2a and 2b with which, through the arms: 3,3a and 3b chains: 4,4a and 4b rotate to the gears: 5,5a and 5b on the shafts: 6,6a and 6b. in the casing head of the arms: 7,7a and 7b.
- f. Carriers of aggregated drill bits: 8,8a and 8b with support in casing head of arms: 7,7a and 7b three-bladed bearings: TN1 and TN2. Through the carriers of aggregated drills, rotation is carried out: variant1.From the axles: 6,6a and 6b through the cone gears: 9,9a and 9b chains, 10 on toothpicks 11 axles 12 that carry drills,variant2. Shafts: 6, 6a and 6b that come from the body of the head of the arms: 7,7a and 7b are articles and carry conveyor belts 14 that carry the drive via conical gears 15 to the shafts 12 on which they are driven aggregated drill 13.
 - g. Shits: 13, which are aggregated on each carrier: 8,8a and 8b.
 - h. Rollers: V1 for handling and compacting the scrubbed soil beneath the schimm and V2 for handling and compacting the shaken (raked, milled) soil above the haymens. Adjusted hydraulically adjusting pillars have four-point support on the supporting structure: NK (in combination, a roller can get a bush).

Method of the functioning of elements and construction as a whole:

Three-beam racks: TN1 and TN2 with bearings on the supporting structure of NK are interconnected in the casing heads: 7,7a and 7b with aggregate drill bits: 8,8a and 8b, which carry aggregated drills 13. They are interconnected with the carriers of aggregated drills: 8,8a and 8b triangular supports TN1 and TN2 rotate around their horizontal axis driven by the HM motor with the gear: Z and Z1 from the axis O to the gear wheels: Z3 and Z4, apparently rolling in the direction of movement as a moving part. The speed of the rotation of the connected three- TN1 and TN2 is regulated and depends on the depth of processing and the required volume of ground aggregates.

The drive from the PTO shaft or hydro motor on the O1 shaft in the TN1 triangular carrier via parallel gears: 2.2a and 2b is diverted through the arms: 3.3a and 3b through the chains: 4.4a, and 4b to the gear wheels: 5.5a and 5b on the shafts: 6,6a and 6b in the casing head of the arms: 7,7a and 7b of the triangular carrier: TN1.For further transfer of the drive to the drill 13, there are two variants.

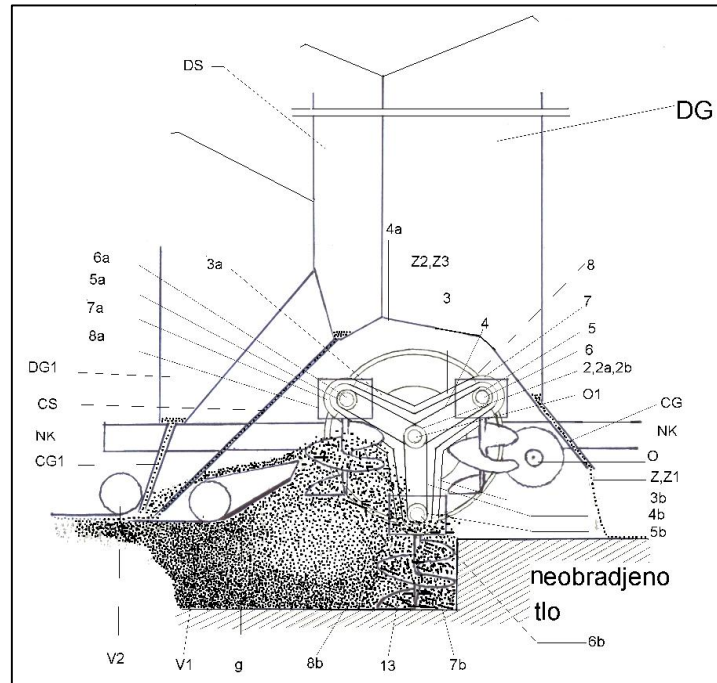

Fig. 1. Accessory machine for single-phase complex agro-technology - vertical cross-section through the triple carrier TN1 - horizontal cross-section through the triple carrier TN1 and TN2, and supports drill bits: 8,8a, 8b and drill bits 13 (variant I, chain link 10)

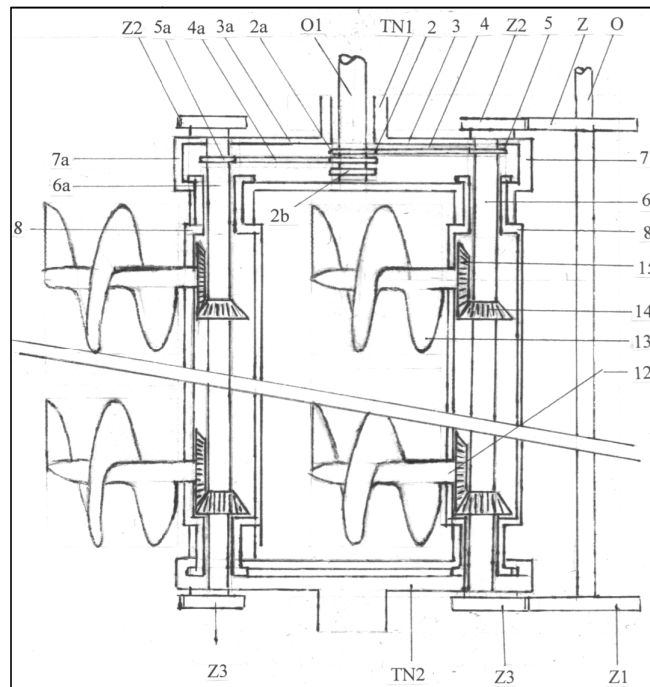

Fig. 2. Accessory machine for monophasic complex agrotechnology Horizontal cross-section through three-beamed bear TN1 and TN2, and bore bearers 8,8a and 8b, and bores 13, with chain transmission 10 (variance 1)

Variant I

Through chains. From the axles: 6,6a and 6b the drive is transmitted in the cone gears: 9,9a and 9b on the aggregate drill bits: 8,8a and 8b on the chains 10 and the gears 11 on the shafts 12 on which the aggregated drills are powered 13.

Variant II

Through the axle made up of several articles.

Shafts: 6,6a and 6b which come from the crankshaft head of the arms: 7,7a and 7b are articulated and carry conical gears 14 which transfer the drive through the conical gears 15 to the shafts 12 on which the aggregated drills 13 are driven.

Driven aggregate drills 13 while simultaneously rotating the moving part of the machine in the form of a roller in the direction of movement, drills the land by cutting it into the spiral tapes that the spiral drill rises, mixes the layers and crushes into aggregates of different fractions where they fall in greater size and subtract the smaller fractions. the roller V1, which runs and pours to the desired degree of compactness, is placed on such ground with CS pipes from the seeds depot for the DS seeds, and the lateral from depot DG pipes CG comes to start fertilizer, and then the upcoming crushed groundmass overlaps and roller V2 straightens and pours up the treated and sown surface. The thickness of the layers and their thicknesses realized by the rollers V1 and V2, or the depth of the laying of the silo can be adjusted hydraulically on the supports rollers.

All technical possibilities in terms of monitoring of work, ie: processing depth, aggregate granulation, compression of the layers and their handling, then the depth of sowing and the number of seeds and their distance and similar actions can also be carried out by methods of electronic control from the control cabin.

Technical possibilities

With a single rotation TN1 and TN2 (three supports with 6 drill bits 330 mm), the surface of the dimension is treated:

Length of the joint is 990 mm (3 x 330 mm), and• Width of the 2100 mm (6 x 330 mm + 5 x 5 mm - the distance between the drill bits).If the drill

speed was 10 o / sec (drive from a hydro motor or a PTO with 600 rpm) at a velocity of 0,33 m / sec or 1,188 km / h, then optimally without empty strokes would process 2,494.5 m² of land surface and depth of 0,33 m.

By reducing the processing depth (25 or 20 cm), the speed of movement and thus the treated surface would increase.

4. CONCLUSION

The speed of movement will depend on the previous condition of the soil, compactness and the desired granulation. The number of rotations of the drill bits and the boreholes with the drill bits and the speed of the machine's movement will always be in coordination, which will determine the quality of soil treatment.

COMPETING INTERESTS

Author has declared that no competing interests exist.

REFERENCES

1. Christmas D. Contribution to the study of minimum tillage for winter wheat in the short term monocultures. Archives for Agricultural Sciences. 1957;27(103). Belgrade. Concaret, J. Structure and Drainage (translation), Zagreb; 1978.
2. Drezgic P, Spasojevic M, Zeravica M. The impact of years of reduced processing, in two-pole crop rotation, on wheat and corn yields. The contemporary field. 1981; 19(1-2). Belgrade. Group of authors: Special farming 1 and 2. Belgrade; 1986.
3. Komarcevic D. Agricultural machines, textbooks Department, Belgrade; 1990. Komljenović I. The possibility of simplified tillage for maize on eutric kambisol Slavonia, Proceedings of Polj, Faculty of Belgrade; 1994
4. Kostadinovic J. Possibility of tillage for wheat with reduced oil content, Agronomist Advice RS, Banja Luka; 1993. Kostadinovic J. Comparative testing of classical and minimal tillage and direct sowing without tillage n the physical properties of the soil, the development and yield of winter wheat and maize in a bipolar field. Contemporary Agriculture. 1982; 30(1-2).

5. Milojić B. Contemporary directions in land processing, contemporary agriculture. Novi Sad; 1972. Milojić B. Ratarstvo, Belgrade, Miljkovic N, Resulovic H. Land Damage and Land Reclamation, Food and Development. Zagreb;1987.
6. Mihalić V. General production of plants, Zagreb; 1976. Racz Z, et al. Agricultural soil mechanics, Zagreb; 1986. Saric T. General Warfare, Sarajevo; 1985. Todorovic J, Bozic D. General farming, Banja Luka-Belgrade; 1995.

© 2020 Veselinovic; This is an Open Access article distributed under the terms of the Creative Commons Attribution License (<http://creativecommons.org/licenses/by/4.0>), which permits unrestricted use, distribution, and reproduction in any medium, provided the original work is properly cited.

Peer-review history:

*The peer review history for this paper can be accessed here:
<http://www.sdiarticle4.com/review-history/54747>*