



# Using Pulse Wide Modulation with Three MQ Sensors to Monitor Synthetic Gas Composition with an Arduino Uno3

**Jean Fidele Nzihou <sup>a\*</sup>, Ousmane Zoundi <sup>a</sup>, Salou Hamidou <sup>b</sup>,  
Bila Gerard Segda <sup>c</sup> and Frederic Ouattara <sup>a</sup>**

<sup>a</sup> *Analytical Chemistry, Spatial Physics and Energetic Laboratory, Norbert Zongo University, Koudougou, Burkina Faso.*

<sup>b</sup> *Catholic University of West Africa, University Unit in Bobo-Dioulasso, Bobo-Dioulasso, Burkina Faso.*

<sup>c</sup> *Environmental Physic and Chemistry Laboratory, Joseph Ki-Zerbo University, Ouagadougou, Burkina Faso.*

## **Authors' contributions**

*This work was carried out in collaboration among all authors. All authors read and approved the final manuscript.*

## **Article Information**

DOI: 10.9734/CJAST/2024/v43i34357

## **Open Peer Review History:**

This journal follows the Advanced Open Peer Review policy. Identity of the Reviewers, Editor(s) and additional Reviewers, peer review comments, different versions of the manuscript, comments of the editors, etc are available here: <https://www.sdiarticle5.com/review-history/112984>

**Original Research Article**

**Received: 03/12/2023**

**Accepted: 08/02/2024**

**Published: 10/02/2024**

## **ABSTRACT**

Commercial gas analyzers are not suited for long time usage and relatively too costly for institutions in underdeveloped countries. Metal oxide sensors have emerged as simple and reliable sensors for gases concentration measurements at an affordable cost. For gasification, carbon monoxide, hydrogen and methane concentration must be monitored at the same time. Hence the need for using three different gas sensors at the same time. SnO<sub>2</sub> based sensor are of SnO<sub>2</sub>-

\*Corresponding author: E-mail: [jfnzihou@edilf.fr](mailto:jfnzihou@edilf.fr);

based gas sensors have been broadly studied to take advantage of the variation of the resistance of metal-oxides thin films. These sensors exhibit a resistor that depends on the nature of the gas flowing between its pins and its concentration in the flue gas. SnO<sub>2</sub>-based gas sensors have a special heating requirement that must be correctly addressed to have meaningful results. This paper reports the methods used and the results obtained to fulfil that heating requirements for three SnO<sub>2</sub> sensors at the same time while avoiding power consumption peaks. Using the Pulse Wide Modulation Technique, we have simultaneously synchronized the heating cycle requirements of three MQ family SnO<sub>2</sub>-based sensors to estimate the concentration of carbon monoxide, hydrogen and methane in synthetic gas produced by a wood-fired co-current downdraft gasifier.

**Keywords:** Concentration; carbon monoxide; hydrogen; methane; pulse wide modulation.

## 1. INTRODUCTION

Up to 90% of the population in Burkina Faso relies on primary energy sources in Burkina Faso for their daily needs as cooking. The drawbacks of that high dependency on primary biomass energy are deforestation and low energetic efficiency. To mitigate those threats to the environment, the development of renewable energy sources has been initiated by the local governments in Burkina Faso [1,2,3,4,5]. Our laboratory has an energetic team who have built its first gasifier from May to September 2022 [6,7]. A second gasifier was designed and built from November to December 2022 to overcome the design flaw that was found in the first gasifier during the testing.

The two gasifiers built are of the co-current type we have chosen because these appeared to us the easiest to build on a small and laboratory testing scale as documented by other authors [8,9,10,11,12,13]. We already have six handheld gas analyzers but these analyzers are not able to measure more than 1000 or 2000 ppm of carbon monoxide and concentrations we got with our gasifiers were quickly out of measurement range of these analyzers. Another problem was that these analyzers don't include hydrogen and methane measurements, whereas hydrogen is one of the most important gases produced by a biomass gasifier. More importantly, the flue gas analyzers we have on hand cannot be used for continuous operation, which is less than 5 minutes of usage for each set of measures as recommended by manufacturers. Having no other gas analyzers, we used these for 30 minutes or more. This resulted in the damage to the oxygen and carbon monoxide sensors. Then we were stuck because these sensors are relatively costly for underdeveloped countries as Burkina Faso. Therefore, we had no choice but to look for other solutions.

As said by Jamal Malallah Rzaij et al. [14]: "Metal oxide gas sensors have many advantages over other solid-state gas monitoring devices, including low cost, ease of manufacture, and small design". We effectively found in the literature that other authors were already using cheap gas monitoring sensors for industrial applications [15,16,17]. We also found that a microcontroller can be used to acquire data from numerous sensors, compute several mathematical functions and display these values [18,19,20]. This is why we anticipated that the combination of these gas sensors with a microcontroller would constitute a cost-effective replacement solution for monitoring gas concentrations in our biomass gasifiers and decided to build an experimental prototype system for measuring these gases, in particular carbon monoxide, hydrogen and methane.

## 2. MATERIALS AND METHODS

### 2.1 Experimental Setup

The gasifier used in this work is composed of several functional units depicted on figure.

- The reactor
- The cyclone
- The condenser
- The filter

MQ gas sensors are located on a sampling box that draw small amount of synthetic gas cleaned of tar and water vapor by the cyclone separator, the condenser and the filter.

### 2.2 Methods

gasification of biomass mainly produces carbon monoxide, hydrogen and methane. Sometime, there is also carbon dioxide produced, but this is not a desirable product, because carbon dioxide

is not flammable, hence doesn't produce heat or usable energy.

We will therefore limit ourselves to three gases: CO, H<sub>2</sub> and CH<sub>4</sub>. In order to lessen power consumption during the heating of the gas sensors, we want that only one of the three sensors be at 5V.

MQ gas sensors have the following internal structure depicted in Fig. 2.

H pins are those of the heater coil. A and B are the sensing pins where the resistance of the MQ sensor which depends on the concentration of the gas is measured. Electrical circuit used for each sensor is the following Fig. 1.

### 2.2.1 Mathematical model of the sensors

Depending on the type of sensor, the manufacturer has provided a standard catalog of correlation curves that we will use.

Curves

$$\log\left(\frac{R_s}{R_0}\right) = f([\text{Conc}]_{(ppm)}) \quad (1)$$

are plotted on a logarithmic scale and are almost linear.

"Conc" denotes the concentration of the gas between pins A and B depicted on Fig. 2.

By changing variables

$$Y = \log\left(\frac{R_s}{R_0}\right) \quad \text{and} \quad X = \log([\text{Conc}]_{(ppm)}) \quad ,$$

theses equation becomes:

$$Y = \alpha * X + \beta \quad (2)$$

Using the coordinates of two points

$(X_1, Y_1)$  and  $(X_2, Y_2)$  , of the sensor characteristic curves, we et get  $\alpha$  and  $\beta$  :

$$\alpha = \frac{Y_1 - Y_2}{X_1 - X_2} \quad (3)$$

$$\beta = Y_2 - \left(\frac{Y_1 - Y_2}{X_1 - X_2}\right) * X_2 \quad (4)$$

Subsequently, we will use the calibration curves provided in the technical datasheets to determine the coefficients  $\alpha$  and  $\beta$  for each sensor according to the type of gas to be detected.

### 2.2.2 Pulse wide modulation with arduino

Owing to Rohini College of Engineering and Technology [22], we can define Pulse Width Modulation (PWM) or Pulse Duration Modulation (PDM) or Pulse Time Modulation (PTM) as an analogue modulating scheme in which the duration or width or time of the pulse carrier varies proportionally to the instantaneous amplitude of the message signal. The width of the pulse varies in this method, but the amplitude of the signal remains constant. Jian Sun wrote that: "Pulse-width modulation (PWM) is the basis for control in power electronics" [23]. Ken Sherrif [24], briefly describe PWM as a digital square wave, where the frequency is constant, but that fraction of the time the signal is on (the duty cycle) can be varied between 0 and 100% and illustrate that as in Fig. 2.

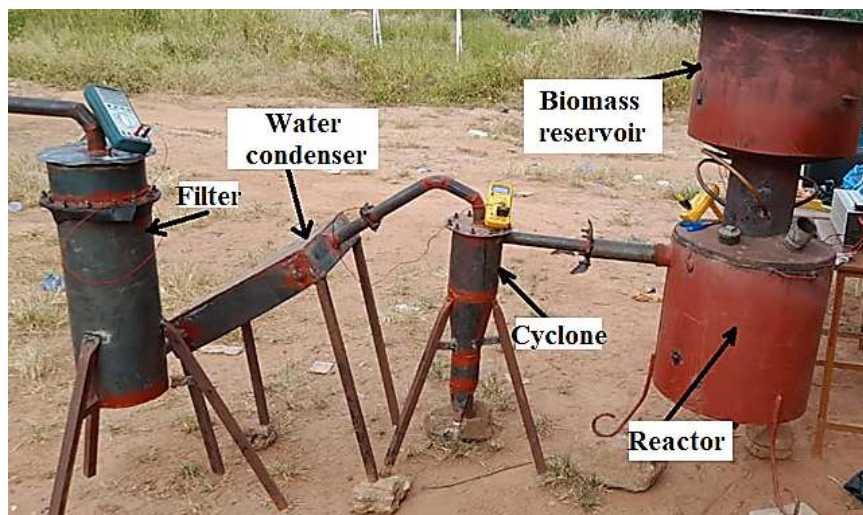

Fig. 1. Picture of the gasifier

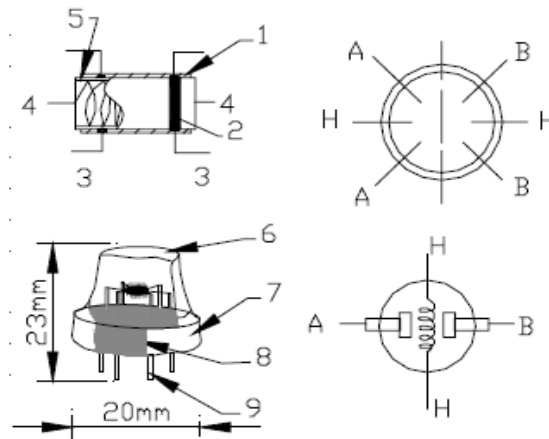

Fig. 2. MQ gas sensors structure [21]

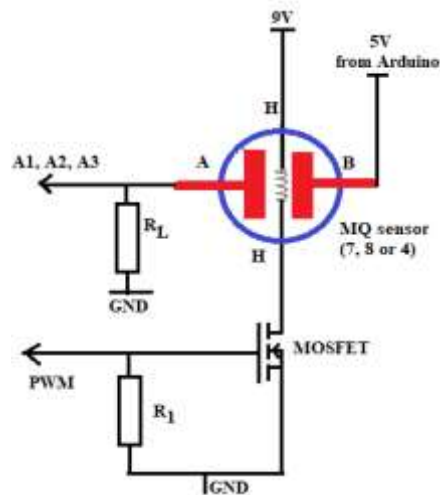

Fig. 3. PWM heating circuit for a MQ sensor

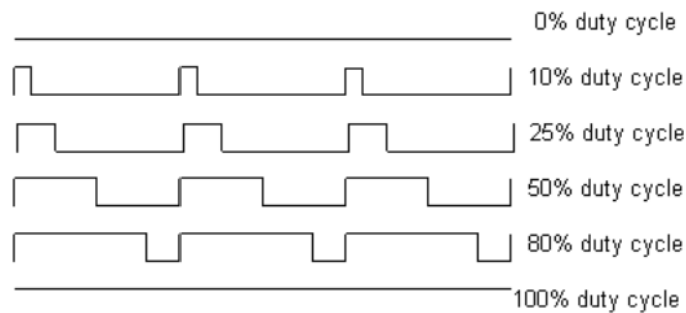

Fig. 4. PWM duty cycles [24]

Timoty Hirzel [25] defines PWM as follows:

“PWM, is a technique for getting analog results with digital means. Digital control is used to create a square wave, a signal switched between on and off. This on-off pattern can simulate voltages in between

the full Vcc of the board (e.g., 5 V on UNO) and off (0 Volts) by changing the portion of the time the signal spends on versus the time that the signal spends off. The duration of "on time" is called the pulse width”.

He explains how to implement it in Arduino as follows:

“In the graphic below Fig. 3, the green lines represent a regular time period. This duration or period is the inverse of the PWM frequency. In other words, with Arduino's PWM frequency at about 500Hz, the green lines would measure 2 milliseconds each. A call to analogWrite() is on a scale of 0 - 255, such that analog Write (255) requests a 100% duty cycle (always on), and analogWrite(127) is a 50% duty cycle (on half the time) for example.

### 2.2.3 Synchronizing MQ sensors heaters

According to the datasheets [21], each of the MQ gas sensor need its heater coil to be cycled with 60s of heating at 5V and 90s of heating at 1.4V as seen.

PWM signal from Arduino only support maximum of 20mA. Heating those 3 MQ sensors directly with Arduino will destroy the board. Therefore, 3 CMOS FET have been used to drive the heating coils of the 3 MQ gas sensors. The overview of that setup.

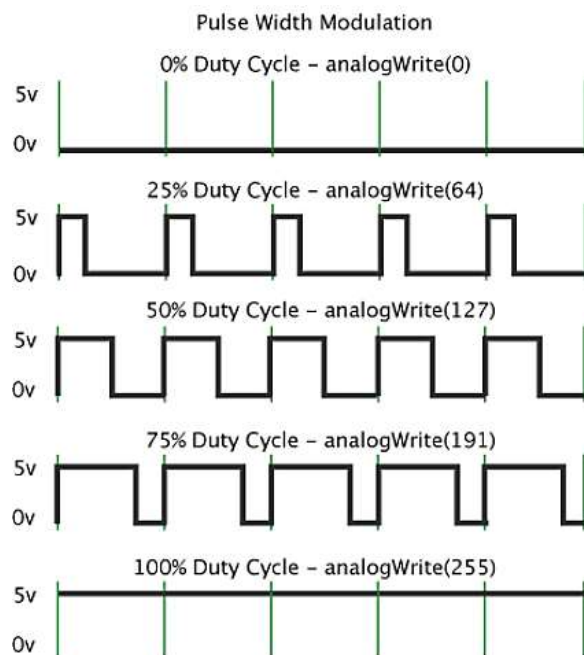

Fig. 5. PWM examples in Arduino [Error! Bookmark not defined.]

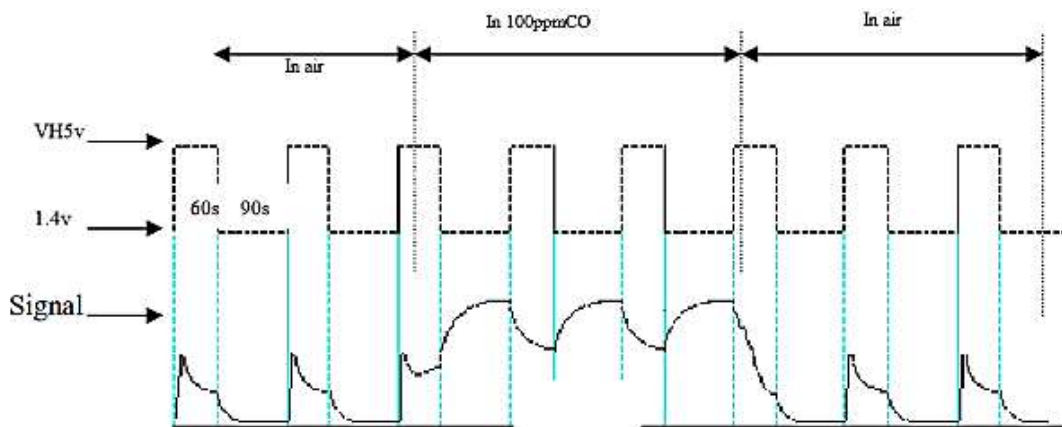

Fig. 6. Heating cycle requirement for MQ sensors [21]

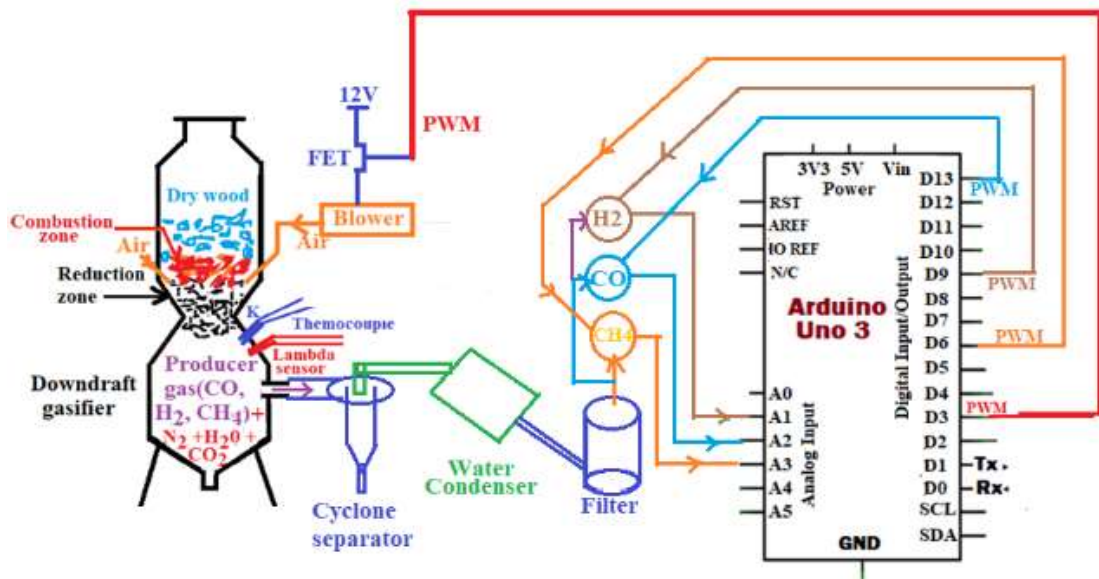

Fig. 7. MQ gas sensors PWM drivers overview

These 3 MQ sensors must be heated as follow:

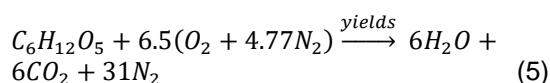

Fig. 8. Heating 3 MQ sensors with only a single one at 5V and the two others at 1.4V

### 2.2.4 Relation to gasification

In case of gasification, we seek to produce mainly carbon monoxide and hydrogen, plus sometime methane.

The stoichiometric combustion of wood in air containing 21% of oxygen and 79% of nitrogen is the following equation:



When oxygen is not supplied in sufficient quantity, CO is also produced in lieu and place of CO<sub>2</sub>. Also, water vapor is engaged in the so-called water-gas shift reaction that produce

From now, we will only measure concentrations of combustibles gas like hydrogen, carbon monoxide and methane. Knowing the concentrations of each of these gases thank to MQ sensors will help us monitor the gasification process.

These gases concentration will be calculated with Arduino Uno 3 board as the microcontroller programmed under Arduino 2.2.1 Integrated Development Environment (IDE).

hydrogen as a reaction between carbon dioxide and water vapor according equation 6 below:

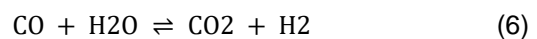

Consequently, we have mixture of CO, H<sub>2</sub>, CH<sub>4</sub>, CO<sub>2</sub> and N<sub>2</sub> from the gasification of biomass.

### 3. RESULTS AND DISCUSSION

#### 3.1 Calibration of the MQ Gas Sensors

Calibration of MQ gases sensors mainly consist in the determination of resistances  $R_s/R_0$ .

Datasheets of the sensors give use the calibration curves, of which equation are of the form:

$$\log\left(\frac{R_s}{R_0}\right) = \alpha * \log(x) + \beta \quad (7)$$

Where  $x$  represents the gas concentration in ppm,  $\alpha$  and  $\beta$  are constants depending on the type of sensor used that can be determined form each sensor datasheet.

We can then can deduce:

$$x(ppm) = 10^{\left(\frac{\log\left(\frac{R_s}{R_0}\right) - \beta}{\alpha}\right)} \quad (8)$$

which can be rewritten as:

$$\frac{R_s}{R_0} = 10^{\beta} * x^{\alpha} \quad (9)$$

and back:

$$x(ppm) = \left(\frac{R_s}{R_0} * 10^{-\beta}\right)^{\frac{1}{\alpha}} \quad (10)$$

From the datasheet, we have calculated the following values of constants  $\alpha$  and  $\beta$  given in the three Table 1 below.

**Table 1.  $\alpha$  and  $\beta$  parameters values for used sensors**

Reference/Gas	$\alpha$	$\beta$
MQ-8/Hydrogen	-1.52	4.57
MQ-7/ Carbon monoxide	-0.653	1.31
MQ-4/Methane	-0.307	0.921

#### 3.2 Electronic Prototype

Prototype we built is show on . The bottle is the gas sampling bottle where MQ gas sensors are affixed. The board is powered with a 9V battery.

#### 3.3 Results Obtained

Values of  $R_s/R_0$  could be calculated once and put in the equation (10) in order to calculate concentrations of combustibles gases in ppm with Arduino. But these values may be modified across the time by environmental conditions such as ambient temperature and relative humidity. Therefore, we take advantage of Arduino computing capabilities to calculate actual values of  $R_s/R_0$  for each sensor, anytime the Arduino Uno 3 board is powered on or reset or the program is reloaded.

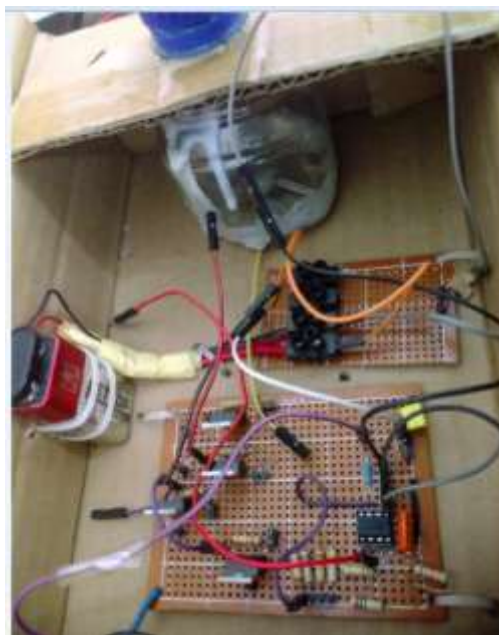

**Fig. 9. Prototype with 4 FET for PWM**

### 3.3.1 Autocalibration of MQ sensors

The program we developed stand on 687 lines of code, including temperature and relative humidity sections. But these sections are very small compared to those of MQ gas sensors. Therefore, all code related to the 3 MQ sensors used couldn't be given in this paper, even in Appendix 1. We summarize results obtained by giving excerpts of our code. Comments in the code begin with two slashes (//) and explain what is done.

As we can see, the setup section end calling function calibration() which have the task of calculating  $R_s/R_0$  values of the 3 MQ sensors that will be used by Arduino to calculate CO, H<sub>2</sub> and CH<sub>4</sub> concentrations in the main loop section of the program.

This result in the following displays.

10 shows at what voltage each sensor is being heating for an interval of time.

After maxcounter=6 heat cycles, averages values of  $R_0$  for each gas sensor is displayed as seen on 11.

A test condition can be inserted in the calibration function. In case  $R_0$  greatly differ from the nominals ones, open circuit or other failure of the sensor can be detected and reported before the measurement could be taken. Success of calibration is announced with total time this have taken as seen in Fig. 12.

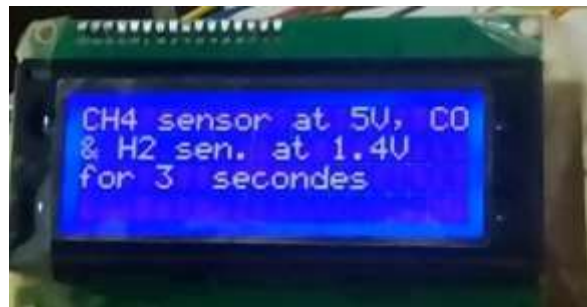

Fig. 10. Continuous heating announcements



Fig. 11. Display of calculated average  $R_0$  values

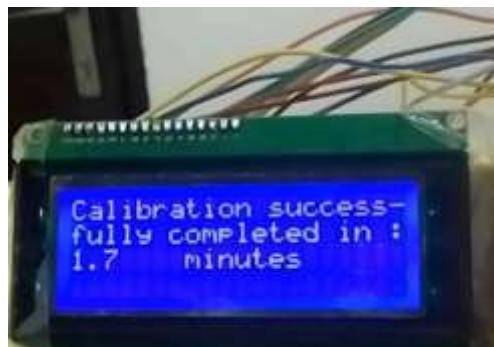

Fig. 12. Total time calibration have taken is displayed at the end



### 3.3.2 Continuous measurements of gases concentrations

The core measurement of our system is the loop of which code is given below:

```
void loop( ) {
//Entering the measurement loop now
enregistrement_mesures(); //Save data in Excel
with PLX-DAQ®
for (int cyc_inter = 1; cyc_inter<=6; cyc_inter++)
{
//Heating cycle and measurement loop
switch (cyc_inter)
{
case 1 : {
analogWrite(pwmCOPin, 255);
//Turn the CO heater coil to 5V
analogWrite(pwmCH4pin, 72);
// turn the CH4 heater to 1.4V
analogWrite(pwmH2pin, 72);
// turn the H2 heater to 1.4V
disp_meas();//Display measured values on the
LCD screen
lcd.setCursor(18,0);//Add visual information other
than measures
lcd.print("C1");
lcd.setCursor(0,3);
lcd.print("CO^Me_Hy_");
delay(intervalHigh);
break;
};
case 2,3,4,5,6: {...}; break;
similar to case 1 above
}; //End switch
}; //End for (6 intervals of a heating cycle)
}; //End loop
Function disp_meas() is called each of the six
cases. It calculate flue gases concentrations and
refreshes the LCD display every 30 seconds. Its
code is given below:
void disp_meas()
{
//We calculate all gas sensors values and other
parameters at once
//Calculate CO in ppm from MQ-7
sensorCO_Read = analogRead(CO_MQ7Pin);
//Read analog values of MQ7 sensor pin
VRLco = sensorCO_Read*(VCco/1023.0);
//Convert Sensor analog signal to voltage
RSCO = ((VCco/VRLco)-1)*RLco; //Calculate RS
in fresh air
ratioCO = RSCO/R0co;//Get resistance ratio
COPpm = pow((19.709/ratioCO),(1/0.652)); //
//Calculate CH4 in ppm from MQ-4
sensorCH4Read = analogRead(CH4_MQ4Pin);
//Read analog values of MQ7 sensor pin
```

```
VRLch4 = sensorCH4Read*(VCch4/1023.0);
//Convert Sensor analog signal to voltage
RSch4 = ((VCch4/VRLch4)-1)*RLch4; //Calculate
RS in fresh air
ratioCH4 = RSch4/R0ch4; // Get resistance ratio
CH4ppm = pow((18.709/ratioCH4),(1/0.652)); //
//Calculate H2 in ppm from MQ-2
sensorH2Read = analogRead(H2_MQ2Pin);
//Read analog values of MQ7 sensor pin
VRLh2 = sensorH2Read*(VCh2/1023.0);
//Convert Sensor analog signal to voltage
RSh2 = ((VCh2/VRLh2)-1)*RLh2; //Calculate RS
in fresh air
ratioH2 = RSh2/R0h2; // Get resistance ratio
H2ppm = pow((17.86/ratioH2),(1/0.482)); //
//Now display all parameters: T, O2, CO, CH4,
H2 and Relative Humidity
lcd.clear(); // Clear LCD to avoid weird
charateres display
//Display Carbon Monoxide MQ8
lcd.setCursor(0,1);
lcd.print("CO ");
lcd.print(COPpm,1);
lcd.print("ppm");
//Display Methane CH4 MQ4
lcd.setCursor(11,1);
lcd.print("CH4 ");
lcd.print(CH4ppm,1);
lcd.print("ppm");
//Display Hydrogen MQ-8, MQ-2
lcd.setCursor(0,2);
lcd.print("H2 ");
lcd.print(H2ppm,1);
lcd.print("ppm");
//Display what is the time elapsed?
lcd.setCursor(9,3);
lcd.print("Tom ");
unsigned long currentMillis = millis();
Tom = ((currentMillis/1000)/60.0);
lcd.print(Tom,1);
lcd.print("mn");
// End calculating and displaying other
parameters
```

The results are displayed on **Error! Reference source not found.3**.

Labels on the LCD display are the following:

- a: Temperature in °C,
- b, i.e. ^: symbolize heating at 5V (CO= carbon monoxide),
- c and d, i.e. \_: symbolize heating at 1.4V (Me=methane, Hy=hydrogen),
- e,f and j: gas concentration in ppm,



Fig. 13. Measured values display labels

Xn: heating cycle, X being C for carbon monoxide, H for hydrogen and M for methane, n takes values 1 to 6 and represent the heating cycle in one loop. For example loop, C1 is the first heating cycle where carbon monoxide sensor is heated at 5V.

### 3.3.3 Saving data in an excel sheet

PLX-DAQ is a registered trademark of the Parallax Company. They offer it for download. There is an Arduino program that could be downloaded and adapted according to one's need.

Major features of the PLX-DAQ include the ability to record up to 26 columns of data, read or write any cell on a spreadsheet, support for

throughputs up to 128 000 baud and support for COM ports 1 to 15. Its basic commands sent through a simple serial port that we used and want to recall are the followings:

- LABEL: Set labels for the topmost row of the Excel sheet.
- DATA: This is the most basic and crucial command of the PLX-DAQ. It is used to send data from Arduino to Excel and print it on the Excel sheet.

Readers interested could simply type PLX-DAQ in Google and they will find all information. After we interfaced it, we obtained results given in Fig. 11

	A	B	C	F	G	J	K	L
1	Date	Heures	Minutes	AFR	FAER	Rco(kOhm)	Rho(kOhm)	Rch(kOhm)
2	28 9 2023	13h	0,2			0,7	0,6	0,6
3	28 9 2023	13h	0,4			1,5	1,3	1,3
4	28 9 2023	13h	0,6	3,16	1,72	2,7	2	2
5	28 9 2023	13h	0,9	3,25	1,68	3,6	2,7	2,7
6	28 9 2023	13h	1,1	3,94	1,38	4,1	3,3	3,3
7	28 9 2023	13h	1,3	3,93	1,19	4,5	4	4
8	28 9 2023	13h	1,6	3,94	1,38	5,1	4,7	4,7
9	28 9 2023	13h	1,9	3,4	1,6	6,7	5,4	5,4
10	28 9 2023	13h	2,1	3,73	1,46	8,1	6,1	6,1
11	28 9 2023	13h	2,3	3,74	1,46	9,2	6,8	6,8
12	28 9 2023	13h	2,6	3,08	1,77	10,8	7,5	7,5
13	28 9 2023	13h	2,8	3,19	1,71	11,5	8,2	8,2
14	28 9 2023	13h	3,1	3,22	1,69	12,2	8,8	8,8
15	28 9 2023	13h	3,3	3,59	1,52	12,6	9,5	9,5
16	28 9 2023	13h	3,6	3,32	1,94	13,1	10,1	10,1
17	28 9 2023	13h	3,9	3,12	1,75	14,3	10,8	10,8
18	28 9 2023	13h	4,1	3,38	1,61	16,4	11,5	11,5
19	28 9 2023	13h	4,3	3,82	1,43	17,7	12,2	12,2
20	28 9 2023	13h	4,6	3,77	1,45	19	12,9	12,9
21	28 9 2023	13h	4,8	3,9	1,4	20	13,6	13,6
22	28 9 2023	13h	5	3,76	1,45	20,4	14,3	14,3
23	28 9 2023	13h	5,3	3,28	1,65	20,9	14,9	14,9
24	28 9 2023	13h	5,5	3,07	1,78	22,2	15,6	15,6
25	28 9 2023	13h	5,8	3,08	1,77	23,5	16,3	16,3

Fig. 14. Data saved on an excel sheet

#### 4. CONCLUSION

Using the Pulse Wide Modulation technic and an Arduino Uno Uno 3, we have successfully fulfilled heating cycle requirements for MQ-8, MQ-7 and MQ-4 gas sensors for measuring Hydrogen, Carbon monoxide and Methane concentrations in flue gas at the same time. Our measurement interval of 30 seconds is achieved within what one measurement was taken. To improve our measurements, a loop can be inserted in the program in order to take for example 15 measures of each gas and then take the average value of these measurements. This measurement method offers a simple autocalibration method that could be used to test the system and make decisions based on the state of the sensors.

#### COMPETING INTERESTS

Authors have declared that no competing interests exist.

#### REFERENCES

1. WAEMU, energy policies component of the IFDD. Access to sustainable energy program, key figures on energy in Burkina Faso and in the WAEMU area, Report. French; 2019.
2. Ministry of energy in Burkina Faso, energy strategy 2019-2023; Report. French. 2018;58.
3. Dabat MH, Hanff E, Blin J. Biofuels, an opportunity to reduce poverty in Burkina Faso, 3rd days of research in social sciences. French. 2009;15.
4. Ministry of mines and energy of Burkina Faso, Project to harness renewable energies as part of pre-electrification to support rural development. French. 1999;5.
5. Sustainable energy for all, [Burkina Faso]: Rapid assessment and gap analysis. French. 2023;1-2. Available: [https://www.seforall.org/sites/default/files/Burkina\\_Faso\\_RAGA\\_FR\\_Released.pdf](https://www.seforall.org/sites/default/files/Burkina_Faso_RAGA_FR_Released.pdf), Accessed 26 septembre 2023.
6. Nzihou Jean Fidele, Hamidou Salou, Imbga Kossi, Segda Bila Gerard, Ouattara Frederic, Tientore Hamadou. Electrical power generation from heat recovered at the throat of a downdraft biomass gasifier. American Journal of Science, Engineering and Technology. 2023; 8(3):133-140. Available: <http://www.sciencepublishinggroup.com/ajset>  
DOI: 10.11648/j.ajset.20230803.12  
ISSN: 2578-8345 (Print);  
ISSN: 2578-8353 (Online)
7. Nzihou Jean Fidele, Hamidou Salou, Segda Bila Gerard, Ouattara Frederic and Compaore Hamidou. Effects of a cyclone dimensions on quality of syngas produced with a wood-fired biomass gasifier. Journal of Energy Research and Reviews. 2023;15(3): 1-14. Article number JENRR.107030, ISSN: 2581-8368,
8. Reed TB, Das A, Handbook of biomass downdraft gasifier engine systems. Solar Energy Research Institute; 1950. Available: <https://www.nrel.gov/docs/legosti/old/3022.pdf>, accessed 15 September 2023
9. Akhator PE, Obanor AI, Sadjere EG. Design and development of a small-scale biomass downdraft gasifier. Nigerian Journal of Technology (NIJOTECH). October 2019;38(4):922–930. Print ISSN: 0331-8443, Electronic ISSN: 2467-8821 Available: <http://dx.doi.org/10.4314/njt.v38i4.15>
10. Mukunda HS, Dasappa S, Paul PJ, Rajan NKS, Shrinivasa U. Gasifiers and combustors for biomass - technology and field studies. Energy for Sustainable Development. 1994;1(3):27-38.
11. Abubakar Bukar A, Ben Oumarou M, Babagana M. Tela Abubakar M. Eljummah assessment of biomass gasification: A review of basic design considerations. American Journal of Energy Research. 2019;7(1):1-14.
12. Chawdhury MA, Mahkamovb K. Development of a small downdraft biomass gasifier for developing countries. Journal of Scientific Research J. Sci. Res. 2011;3(1):51-64. Available: [www.banglajol.info/index.php/JSR](http://www.banglajol.info/index.php/JSR)
13. Nikhil Ashok Inglea, Sanjay Shridhar Lakade. Design and development of downdraft gasifier to generate producer gas, 5th International Conference on Advances in Energy Research, ICAER 2015, 15-17 December 2015, Mumbai, India, Science Direct, Energy Procedia. 2016;90:423–431.

14. Jamal Malallah Rzaij, Sameer Obaid Nawaf, Ahmed Khalil Ibrahim. A review on tin dioxide gas sensor: The role of the metal oxide doping, nanoparticles and operating temperatures. *World Journal of Advanced Research and Reviews*. 2022;14(01):051–062.  
DOI:<https://doi.org/10.30574/wjarr.2022.14.1.0288>
15. Kadek Nuary Trisnawan I, Agung Nugroho Jati, Novera Istiqomah, Isro Wasisto. Detection of gas leaks using the MQ-2 gas sensor on the autonomous mobile sensor.
16. Nisal Kobbekaduwa, Pahan Oruthota, W.R. de Mel. Calibration and implementation of heat cycle requirement of MQ-7 semiconductor sensor for detection of carbon monoxide concentrations. *Advances in Technology*. 2021;1(2):377-392.
17. Sohibun I Daruwati, Hatika RG, D Mardiansyah. MQ-2 gas sensor using micro controller arduino Uno for LPG leakage with short message service as a media information, URICSE 2021. *Journal of Physics: Conference Series*; 2021. 012068 IOP Publishing,  
DOI:10.1088/1742-6596/2049/1/012068
18. Abubakar Yakub Nasir, Bature UI, Tahir NM, Babawuro AY, Aduyi Boniface, Hassan AM. Arduino based gas leakage control and temperature monitoring system. *International Journal of Informatics and Communication Technology (IJ-ICT)*. December 2020;9(3):171-178.  
ISSN : 2252-8776,  
DOI : 10.11591/ijict.v9i3.pp171-178  
Available:<http://ijict.iaescore.com>, 2020
19. Huan Hui Yan, Yusnita Rahayu. Design and development of gas leakage monitoring system using arduino and ZigBee. *Proceeding of International Conference on Electrical Engineering, Computer Science and Informatics (EECSI 2014)*, Yogyakarta, Indonesia; 20-21 August 2014.
20. Dewi L, Somantri Y. Wireless sensor network on lpg gas leak detection and automatic gas regulator system using Arduino, *IOP Conf. Serie: Material Sciences Engineering*. 2018;384: 012064.
21. Hanwei Eletronics Co.,LTD, Technical data MQ-7 gas sensor.  
Available:<https://datasheetspdf.com/pdf/694312/Hanwei/MQ7/1>  
Accessed 20 september 2023.
22. Rohini College of Engineering and Technology, EC8491 Communication Theory,  
Available:[https://rcet.org.in/uploads/academics/rohini\\_58510678608.pdf](https://rcet.org.in/uploads/academics/rohini_58510678608.pdf),  
Accessed 27 september 2023.
23. Jian Sun, Pulse-Width Modulation, Chapter 2.  
Available:<https://www.iforap.org.au/wp-content/uploads/2014/04/9781447128847-c2.pdf>,  
Accessed 28 September 2023.
24. Ken Shirriff. Secrets of Arduino PWM.  
Available:<http://www.righto.com/2009/07/secrets-of-arduino-pwm.html>,  
Accessed 14 September 2023.
25. Timoty Hirzel. Basics of PWM.  
Available:<https://docs.arduino.cc/learn/microcontrollers/analog-output/>  
Accessed 28 September 2023

## APPENDIX 1

```
#include <LiquidCrystal.h>
LiquidCrystal lcd(12,8,13,4,3,2); //Declare LCD display pins
//MQ sensors pins definition
int CO_MQ7Pin = A1; // MQ7 pin for CO sensor
int CH4_MQ4Pin = A2; // MQ4 pin for CH4 sensor
int H2_MQ2Pin = A3; // MQ8 pin for H2 sensor
//Pulse Wide Modulation for MQ sensors
int pwmCOpin = 9; // PWM signal to the heating circuit of CO
int pwmCH4pin = 10; // PWM... to CH4
int pwmH2pin = 11; // PWM... to H2
//For Carbon monoxide
float VC=5.0; //Supply DC voltage for all sensors
float R0co = 1.12; // Average R0 value measured and calculated during calibration for CO
float R0ch4 = 1.25; // Average R0 value ... for CH4
float R0h2 = 1.04; // Average R0 value measured ... for H2
float R0_co=0.0; // R0 value measured and calculated during calibration for CO
float R0_ch4=0.0; //R0 ... for CH4
float R0_h2=0.0; //R0 ... for H2
//Define averages values for a heating cycle
float av_R0_co=0.0; // average R0 value calculated in a heating cycle for CO
float av_R0_ch4=0.0; //av. R0 for CH4
float av_R0_h2=0.0; //av. R0 for H2
//WE define values of Rs/Ro in ambient air for CO, CH4 and H2
float ambCO = 27.75; //MQ-7
float ambCH4 = 4.6; //MQ-4
float ambH2 = 9.75; //MQ-8
float CH4_VRL;
//Define variable for sensor voltage for CH4
float CH4_RS; //Define Rs for CH4
float CH4_R0; //Define R0 for CH4
float CH4_sensorRead=0.0; //CH4 analog readings
float CH4_RL=10; //Load Resistance (Units are Kilo Ohms) for CH4
//MQ-8 and MQ-2 calibration variables definition
float H2_VRL; //Define variable for sensor voltage for H2
float H2_RS; //Define Rs for H2
float H2_R0; //Define R0 for CH2
float H2_sensorRead=0.0; //H2 analog readings
float H2_RL=10; //Load Resistance H2
//End def. of ROxx and Rs values
//****MQ-7****
float sensorCO_Read= 0.0 ; //Define variable for analog readings for CO
float RScO; //CO sensor resistance
float ratioCO; //CO resistance ratio
float VRLco; //CO sensor voltage
float VCco= 5.0; //Supply Voltage
float RLco= 10; //Load Resistance
double COppm; //CO in ppm
//***MQ-4*****
float sensorCH4Read= 0.0; //Define variable for analog readings for CH4
float RSch4; //Define variable for sensor resistance
float ratioCH4; //Define variable for resistance ratio
float VRLch4; //Define variable for sensor voltage
float VCch4= 5.0; //Supply Voltage
float RLch4= 12; //Load Resistance
double CH4ppm; //Methane in Parts per Million
```

```
****MQ-2*****
float sensorH2Read= 0.0;//Define variable for analog readings for CH4
float RSh2; //H2 sensor resistance
float ratioH2; //H2 resistance ratio
float VRLh2; //H2 sensor voltage
float VCh2= 5.0; //Supply Voltage
float RLh2= 15; //H2 load resistance double H2ppm; //Hydrogen in ppm

#define maxcounter 6 //Calibration heat cycles
long unsigned intervalHigh = 3000; // 30 seconds; 3 secondes tests
long unsigned calib_time;
unsigned long count;
float Tom = 0.0; //Time of measure
```

After we have defined these variables, we set values of the main program as follow:

```
void setup() {
Serial.begin(9600);//Serial port
pinMode(vccPin, OUTPUT); digitalWrite(vccPin, HIGH);
pinMode(gndPin, OUTPUT); digitalWrite(gndPin, LOW);
pinMode(CO_MQ7Pin, INPUT);// To get input from the MQ7 CO sensor
pinMode(CH4_MQ4Pin,INPUT);//CH4
pinMode(H2_MQ2Pin,INPUT);//H2
pinMode(pwmCOpin,OUTPUT);//CO PWM
pinMode(pwmCH4pin,OUTPUT);//CH4 PWM
pinMode(pwmH2pin,OUTPUT);//H2 PWM
//Setup LCD display
lcd.begin(20,4); //set up the LCD's number of columns and rows:
lcd.clear();
lcd.print("Powering on. Please wait...");
delay(1500); //Give reader 1.5 //second to read the display
//when starting the sketch
lcd.clear();
lcd.print("Sensors calibration in progress");
delay(1500); //Give reader 1.5 second to read the display
calibration();
}; //End setup
```

---

© 2024 Nzihou et al.; This is an Open Access article distributed under the terms of the Creative Commons Attribution License (<http://creativecommons.org/licenses/by/4.0>), which permits unrestricted use, distribution, and reproduction in any medium, provided the original work is properly cited.

*Peer-review history:*  
*The peer review history for this paper can be accessed here:*  
<https://www.sdiarticle5.com/review-history/112984>